

Factory Automation



Application Brief

Industrial



DDC, the leader in high reliability data networking, power control and motion control technology for the aerospace and defense industry, offers field proven integrated circuit and subsystem solutions for high precision industrial applications.

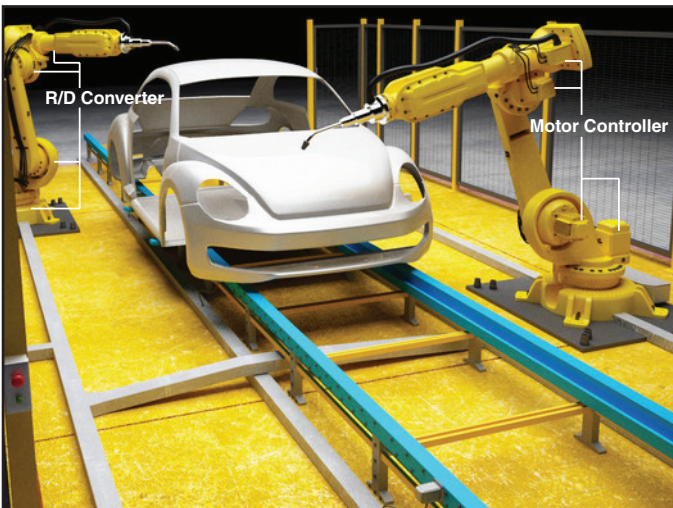

The DDC Advantage:

Factory Automation demands technology that is engineered to operate with consistent repeatable precision at high duty cycles. System components must provide high accuracy, reliability, and repeatability, as well as velocity control and high power density, in a compact package. Our product solutions provide:

- High Precision Motion Feedback Technology
 - Up to 16-bit Resolution Analog-to-Digital Conversion
 - Up to 1 Arc Minute Accuracy
 - Flexible Interface Options with High-levels of Integration
- Turnkey Motor Control Solutions
 - Proven DSP-based Architecture Enables Flexible Tuning to Optimize Motor Performance
 - Flexible Solutions for Various Power and Current Requirements, 28V to 600V and up to 30A
 - Robust Software Tools and Support Accelerate Time-to-Market

Applications:

- AC and DC Servo Motor Control
- Brushless DC Motors (BLDC)
- Electric Actuators, Gantry Robots & Slides
- Electric Pumps and Valve Controls
- Electromechanical Actuation Systems
- Linear Motors
- Robotic Control
- Structural Extrusions

Your Solution Provider for Connectivity, Power, and Control... For over 50 years, DDC has continuously advanced the state of high-reliability data communications and control technology with innovations that have minimized component size and weight, while increasing performance. DDC is distinguished with top industry certifications for our controlled processes, clean room manufacturing, and state-of-the-art production equipment. Our products have been deployed on military and commercial aerospace platforms, ground vehicles, underwater unmanned vehicles, and space applications.

For more information: www.ddc-web.com/factoryautomation

Motor Positioning and Feedback

Resolver-to-Digital Converters

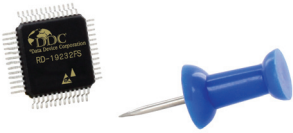

DDC's Resolver-to-Digital converters offer programmable resolution, dual bandwidth, and tracking rate. These A/D converters have SPI, Parallel, and Encoder Emulation (A Quad B) interface output options, and are available in 64-Pin and 52-Pin QFP Packages. All are engineered for rugged environments exposed to extreme temperature, shock, vibration, dust, and fluid.

Feature Summary	RD-19230	RD-19232	RD-19240	RD-19242
R/D Interface	Parallel, AqB	Serial, AqB	Parallel, AqB	Serial, AqB
Integrated Reference Oscillator	-	✓	-	✓
Programmable Resolution	10, 12, 14, 16 Bits	10, 12, 14, 16 Bits	10, 12, 14 Bits	10, 12, 14 Bits
Accuracy	1 Arc Minute	2 Arc Minutes	8 Arc Minutes	8 Arc Minutes
Package Options	10mm ² 64 QFP, RoHS	10mm ² 52 QFP, RoHS	10mm ² 52 QFP, RoHS	10mm ² 52 QFP, RoHS
Temperature Range	-40°C to +85°C	-40°C to +85°C	-55°C to +125°C	-55°C to +125°C

Motor Drive and Control

3-Phase BLDC Motor Controller



DDC's high performance, flexible motor controllers offer a turnkey solution, designed to precisely regulate current into the motor windings of 3-phase brushless DC motors used in applications requiring high position accuracy. These controllers provide 7% Linearity, 3 % current regulating accuracy, with holding torque through zero current and cycle-by-cycle current limits. All have a temperature range of -40°C to +100°C in a compact 81mm x 66mm (3.2in x 2.6in) package.

Feature Summary	PW-82530	PW-82535	PW-82537	PW-82560
Max Bus Voltage	100V	100V	250V	100V
Output Current	10A	10A	20A	30A
Type of Motor Control	Torque	Torque & Speed	Torque & Speed	Torque, Speed, & Position
Communication	Hall Sensor	Hall Sensor	Hall Sensor	Hall Sensor/Sensorless
Command Interface	Analog or USB	Analog or USB	Analog or USB	Analog, CANbus, RS232, RS485
PWM Frequency	10kHz - 25kHz	10kHz - 25kHz	10kHz - 50kHz	10kHz - 100kHz
Software Support	Terminal (Text) Emulator	Terminal (Text) Emulator	Terminal (Text) Emulator	GUI

Block Diagram

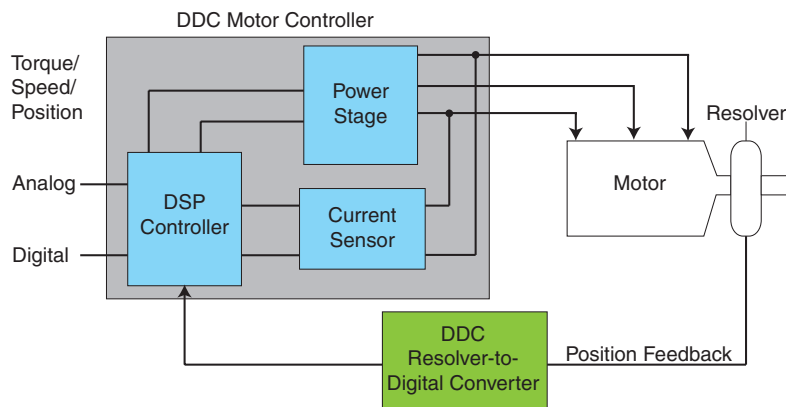

Custom Hybrid, MCM, and PCB Solutions

DDC designs boards, hybrids and multi-chip modules (MCM) to meet ruggedness and reliability levels for performance in the most demanding environments. Our expertise lies in our engineering and manufacturing abilities to reduce size, weight and power while providing the highest level of integration into small single packaged solutions.

Quality

- Underwriters Laboratories (UL) Certified:
 - ISO 9001: 2008 Certified
 - AS9100, Rev. C Compliant
 - EN9100 Compliant
 - JIS Q9100 Compliant
- Defense Supply Center Columbus (DSCC) Certified:
 - MIL-PRF-38534 Class D, G, H, & K



For ordering assistance and technical support,

Call: 1-800-DDC-5757 for North America

(631) 567-5700 for International

E-Mail: service@ddc-web.com

Visit: www.ddc-web.com

Headquarters, N.Y., U.S.A - Tel: (631) 567-5600, Fax: (631) 567-7358

United Kingdom - Tel: +44-(0)1635-811140, Fax: +44-(0)1635-32264

France - Tel: +33-(0)1-41-16-3424, Fax: +33-(0)1-41-16-3425

Germany - Tel: +49-(0)89-1500-12-11, Fax: +49(0)89-1500 12-22

Japan - Tel: +81-(0)3-3814-7688, Fax: +81-(0)3-3814-7689

Asia - Tel: +65-6489-4801



The information in this Flyer is believed to be accurate; however, no responsibility is assumed by Data Device Corporation for its use, and no license or rights are granted by implication or otherwise in connection therewith. Specifications are subject to change without notice.